

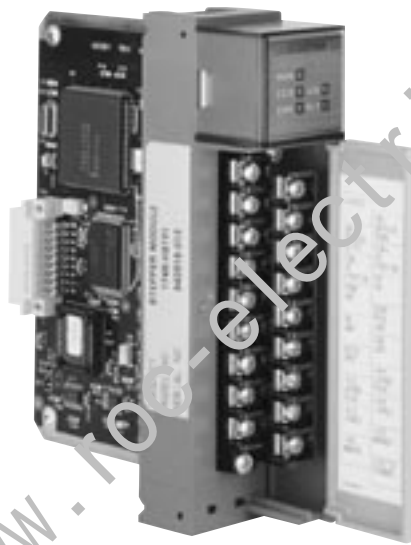

SLC™ Based Stepper Module

Product Data

Catalog Number 1746-HSTP1



This publication provides product information about the single-axis 1746-HSTP1 Stepper controller module. This publication includes:

- SLC Stepper description and a list of the features available for the single-axis 1746-HSTP1 stepper controller module
- Discrete I/O and motion requirements
- Hardware overview
- System overview
- Typical wiring configurations
- General specifications

Table of Contents

SLC Stepper Description	3
Discrete I/O and Motion Requirements	4
Discrete Inputs	4
Discrete Outputs	4
Feedback Circuitry	4
Program Storage Requirements	5
Types of Motion	5
Hardware Overview	5
Hardware and Performance Specifications	5
LED Indicators	6
Input/Output Terminals	6
System Overview	7
Typical Stepper Configuration	7
Typical Wiring Configurations	8
Wiring for a Differential Interface	8
Wiring for Optocoupler Interfaces	9
Wiring for a TTL Interface	10
General Specifications	11
Power Requirements	11
Storage and Operating Conditions	11
Effect on SLC Processor Scan Time	11

SLC Stepper Description

The 1746 stepper controller is a single-slot module that is capable of operating with a wide variety of SLC 500™ series processors. It is capable of providing up to 250 kHz pulse train output for micro-stepping applications.

The SLC™ Stepper Module is intended for open loop stepper applications that only require one axis of control. The program and configuration information are all contained within the SLC Processor's data table. The Stepper Controller Module offers unique features with built-in Loop Back Diagnostics that permit monitoring of the commands to the Stepper motor Driver/Translator. The module is easy to install and program.

You can program and commission the system using RSLogix 500™ or AI 500 programming software. Using the values stored in the data table you can program the distance, acceleration, deceleration and velocity of a given move profile. For programming SLC 5/01™ and SLC 5/02™ processor, and data table entries for the stepper controller, you may also use the Hand Held Terminal (1747-PT1). This requires firmware revision Catalog Number 1747-PTA1E.

Each stepper module features:

- **SLC 500 System Compatibility** - The Stepper controller, the heart of the positioning loop, is an intelligent module that resides in the 1746 SLC 500 I/O Chassis with other 1746 I/O modules. The module works directly with compatible Allen-Bradley® programmable controllers and encoders. Compatible SLC™ processors include the fixed units used with the 2-slot expansion rack, SLC 5/01, SLC 5/02, SLC 5/03™, SLC 5/04™, and SLC 5/05™ models. It is also compatible with larger PLC® programmable controller systems via the 1747-ASB module interface.
- **Operational Characteristics** - The Stepper controller is capable of over $\pm 8,000,000$ counts of absolute positioning at pulse train velocities of up to 250 KHz. This is not a closed loop controller but an encoder can be connected to the module to verify that the axis moved to the proper position in your application's program.
- **Encoder** - The Stepper controller can accept position feedback from a single encoder. It interfaces directly with +5 or +15V encoders that provide differential feedback.
- **Translator Compatibility** - The Stepper controller will be compatible with translators with differential inputs, and single-ended TTL and opto coupler interfaces. The controller can be configured for pulse train and direction bit or CW and CCW pulse train outputs.
- **Local I/O** - The module will support user inputs for: external interrupts, Home Limit Switch, Home Proximity Limit Switch, CW and CCW Travel Limit Switches, Emergency Stop Switch, and Differential inputs for encoder Channels A, B, and the Marker Channel. The encoder can be used to verify that the axis reached the desired commanded position.
- **No Switches to Set** - The Stepper controller does not require the setting of any DIP switches for operation or configuration. All characteristics are established by the application's program written in RS Logix 500 or AI 500 used for the SLC Processor.

- **Built-in Loop-back Diagnostics** - The Stepper module monitors the pulse train commands issued to the Stepper motor driver/translator. Discrepancies between the number of pulses commanded and those read back provide a means to detect possible electrical interference in the process.
- **LED Status Indicators for Prompt Status Information and Troubleshooting Help** - The LED status indicators provide a quick visual indication to aid in identification of the module status and error conditions. Red LEDs are used to indicate configuration or programming errors. Green LEDs indicate normal operation of the module.
- **Independent Acceleration and Deceleration Values for a Move** - The controller will provide the ability to have independent acceleration and deceleration values for a programmed motion. If the move is too short to reach the programmed velocity, it will complete as a triangular motion profile.

Discrete I/O and Motion Requirements

This section contains descriptions of the discrete inputs and outputs, the optional feedback circuitry, program storage requirements, and the two types of motion profiles.

Discrete Inputs

Input	Description
External Interrupt	
Home Limit Switch	
Home Proximity Input	Single-ended (12-24V DC)
CW Travel Limit Input	
CCW Travel Limit Input	
Pulse Train Enable/Disable	
Encoder Channel A	Differential (5V DC)
Encoder Channel B	
Encoder Marker Channel	

Discrete Outputs

Output	Description
CW or non-directional pulse output	Differential Output
CCW pulse or direction signal output	

Feedback Circuitry

There is no feedback circuitry required.

Note: Use optional Differential A quad B Encoder with marker channel to verify that the axis has reached the desired commanded position.

Program Storage Requirements

Requirement	Description
Applications Program Storage	No local storage (uses SLC processor)
Applications Parameters Storage	No local storage (uses SLC processor)
Module Address	Determined by chassis location
Homing Method	Determined by backplane configuration

Types of Motion

Figure 1

Trapezoidal velocity profiles with programmable acceleration/deceleration



Figure 2

Blended velocity profiles with high-speed traverse and low-speed positioning moves



Hardware Overview

This section contains hardware and performance specifications, descriptions of the LED indicators and a diagram of the input/output terminals.

Hardware and Performance Specifications

Specification	Description
Number of Axes	1
Applicable Interfaces	Stepper motor driver
Pulse Train Switching	7 to 30 ma @ 5V DC
Speed Range	1 to 250,000 pulses per second
Acceleration	2 to 2500 pulses per second ² Trapezoidal velocity profile
Acceleration Step Rate	4 milliseconds or less

The SLC 500 Stepper Module is UL[®]-Listed, CSA-Certified and CE-Marked.

Note: Backplane is isolated to protect other modules and the processor from external transient voltages.

Note: Motion is inhibited whenever the power up sequence is in progress or the SLC processor is placed in program mode.

LED Indicators

Specification	Color	Description
RUN LED	Green	Processor is running (extinguished in case of watchdog timeout)
CW LED	Green	Clockwise motion
CCW LED	Green	Counter-clockwise motion
Error LED	Red	Data transfer error
Fault LED	Red	Module cannot communicate

Input/Output Terminals

Figure 3
Input/Output Terminals

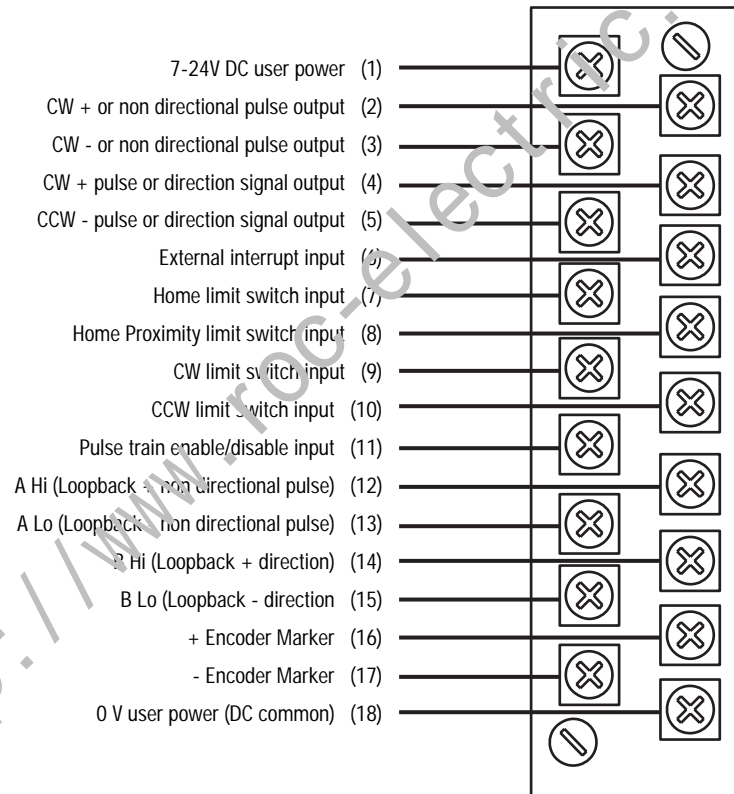

Note: These terminals supply power and inputs to the module and outputs to attached devices. They can accommodate two #14 gauge wires.

Note: Terminal block release screws are attached to the terminal block in such a way that when the screws are loosened, the terminal block moves away from the module.

System Overview

This section illustrates how to configure a SLC Stepper Controller system. Included are simplified drawings showing the required components. For further information, contact your local Allen-Bradley sales representative.

Typical Stepper Configuration

Figure 4
Typical Stepper Configuration

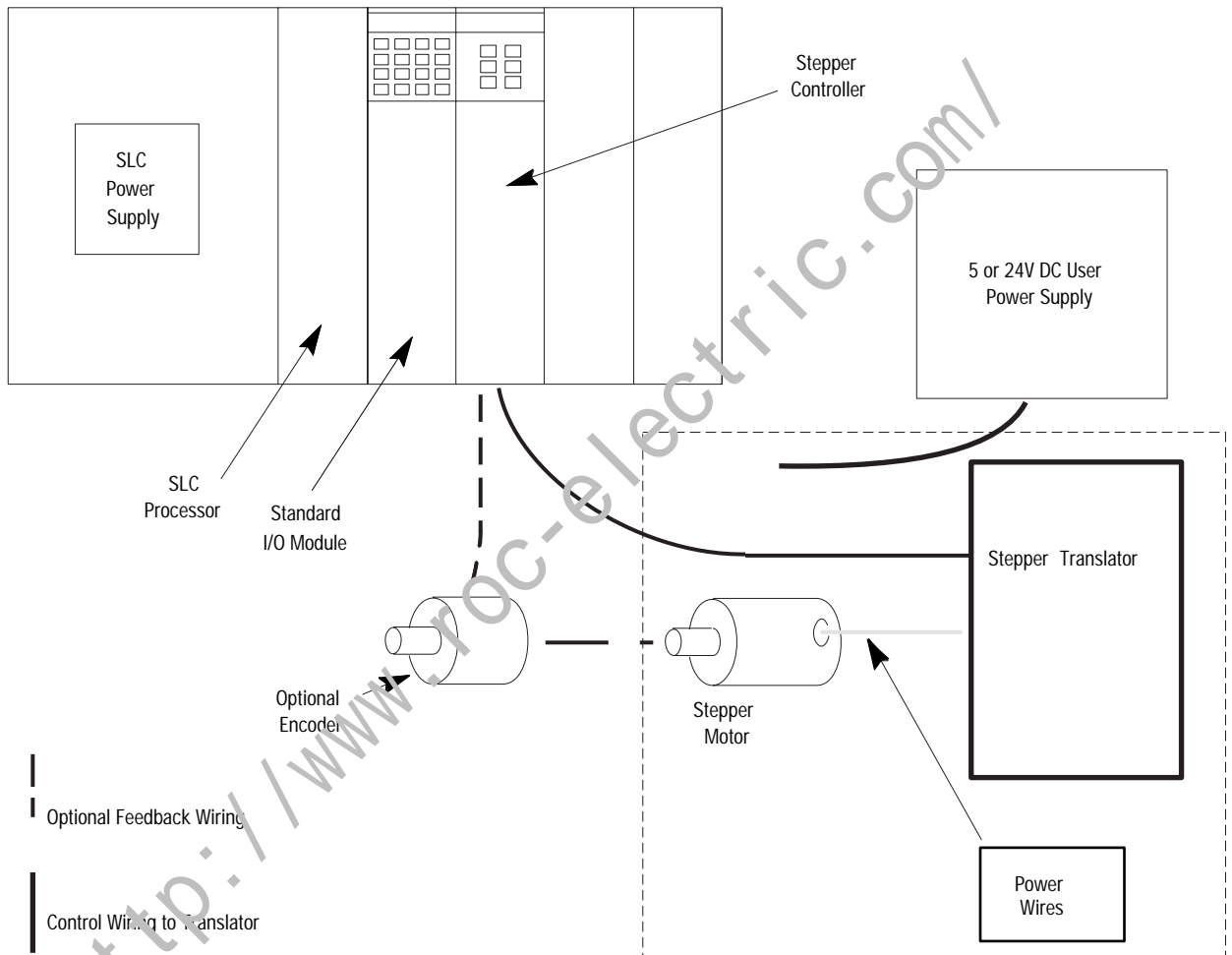

Typical Wiring Configurations

This section contains interconnection wiring diagrams for stepper translators that have differential, optocoupler, and TTL interfaces.

Wiring for a Differential Interface

Figure 5
Differential Interface Interconnection Diagram

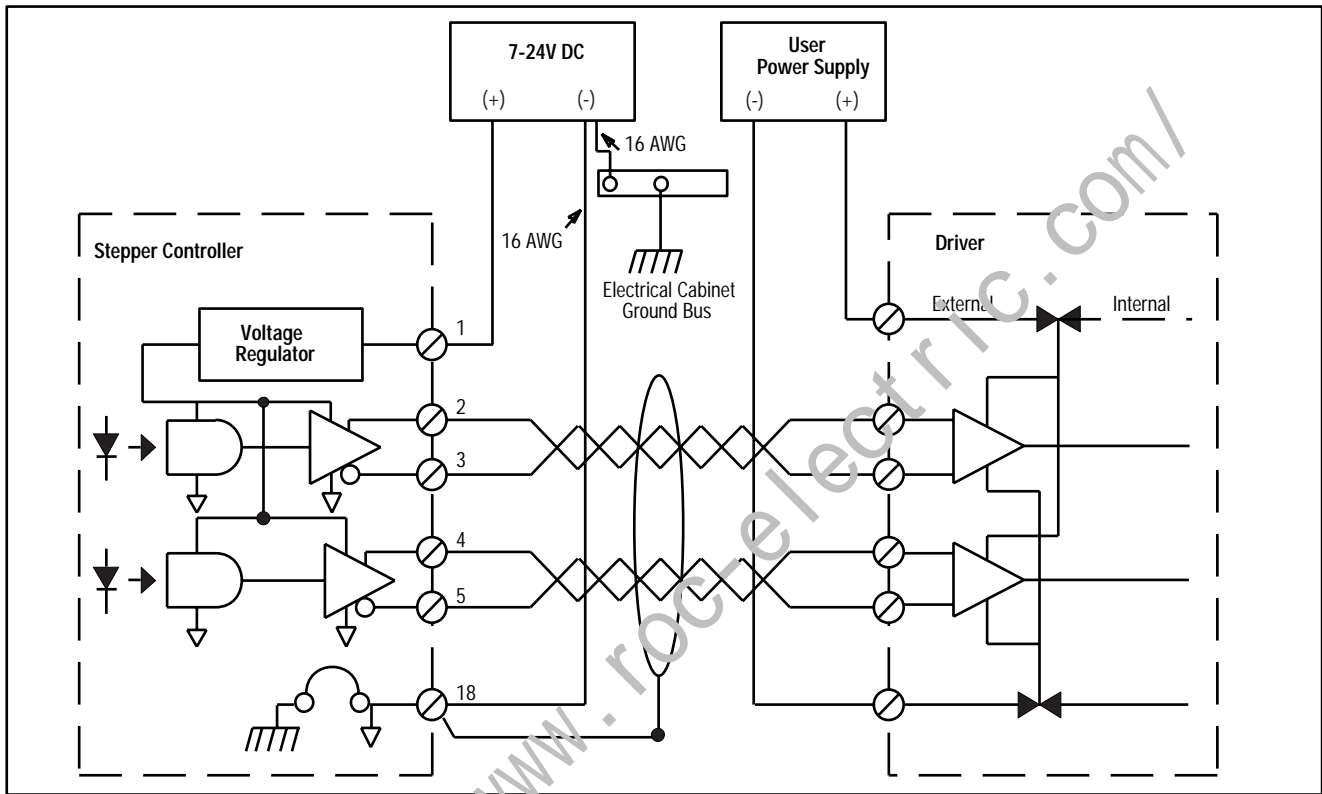

Wiring for Optocoupler Interfaces

Figure 6
Optocoupler Interface Interconnection Diagrams

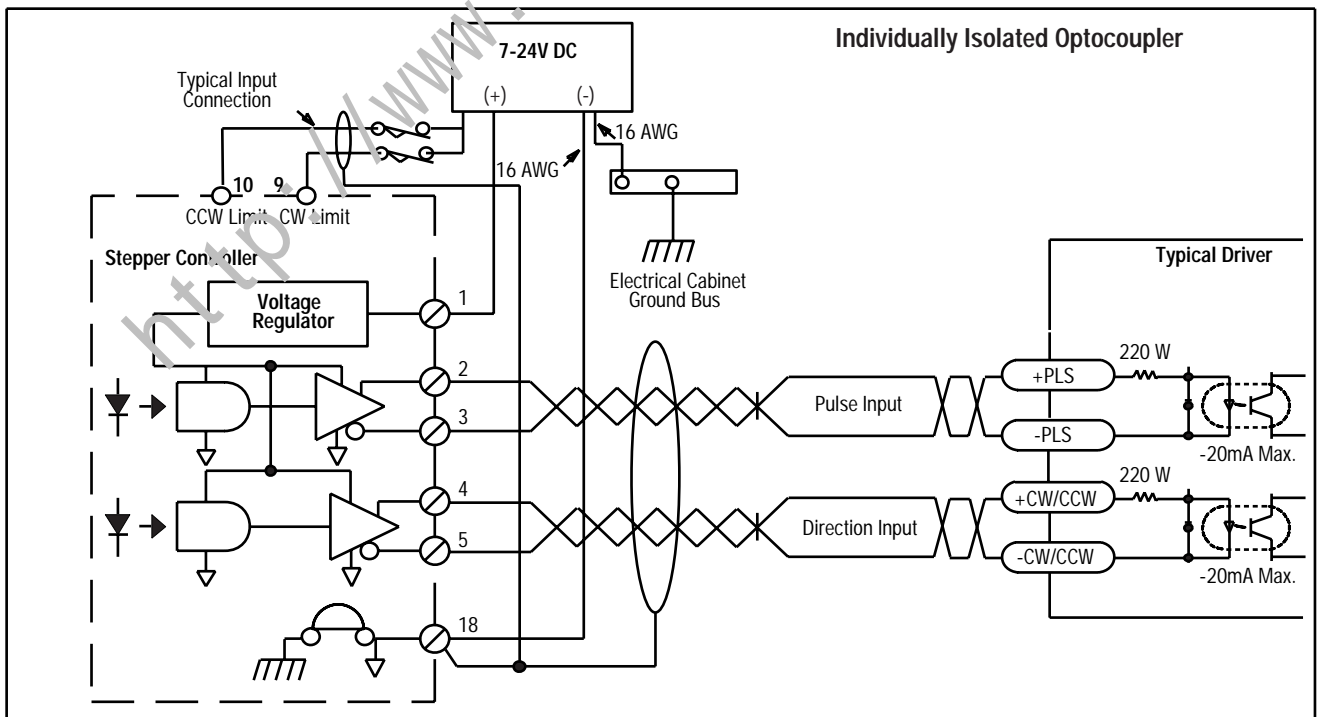
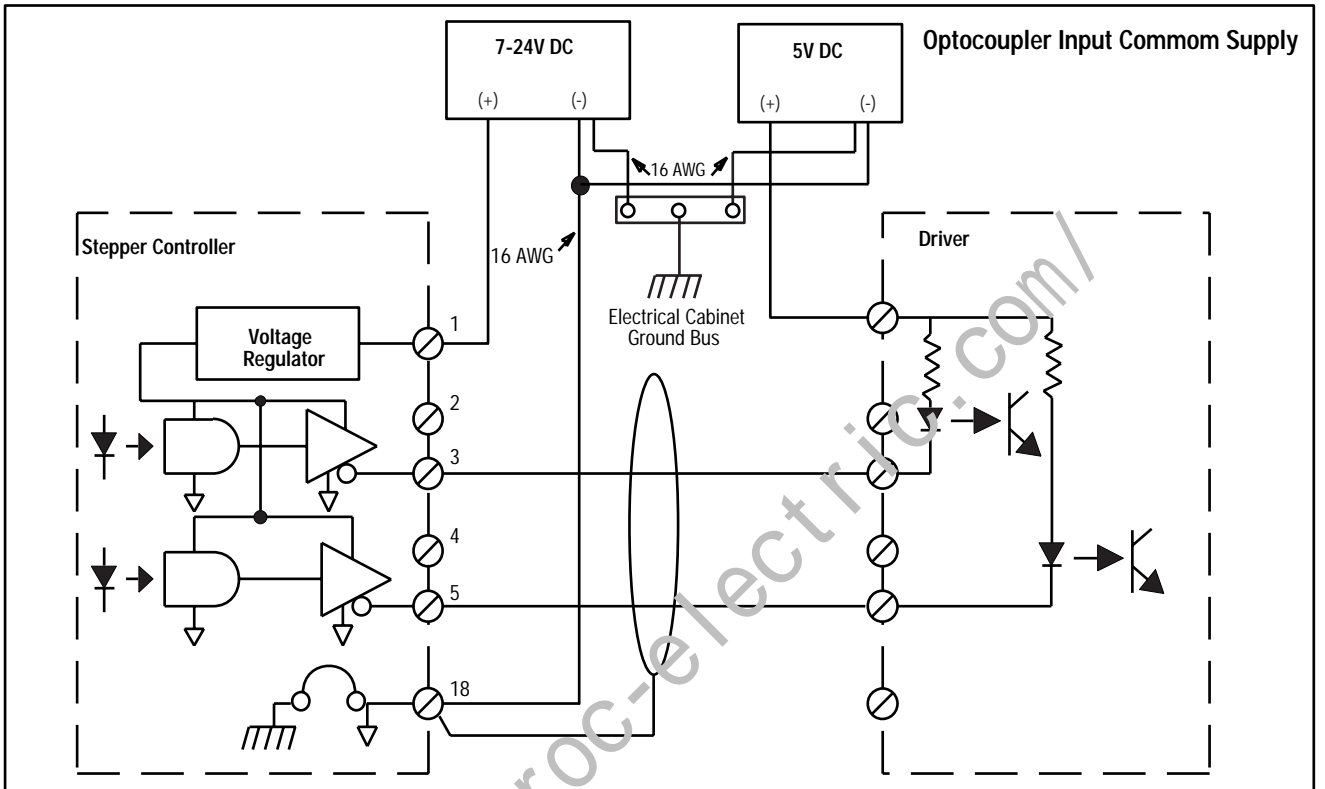

Wiring for a TTL Interface

Figure 7
TTL Interface Interconnection Diagram

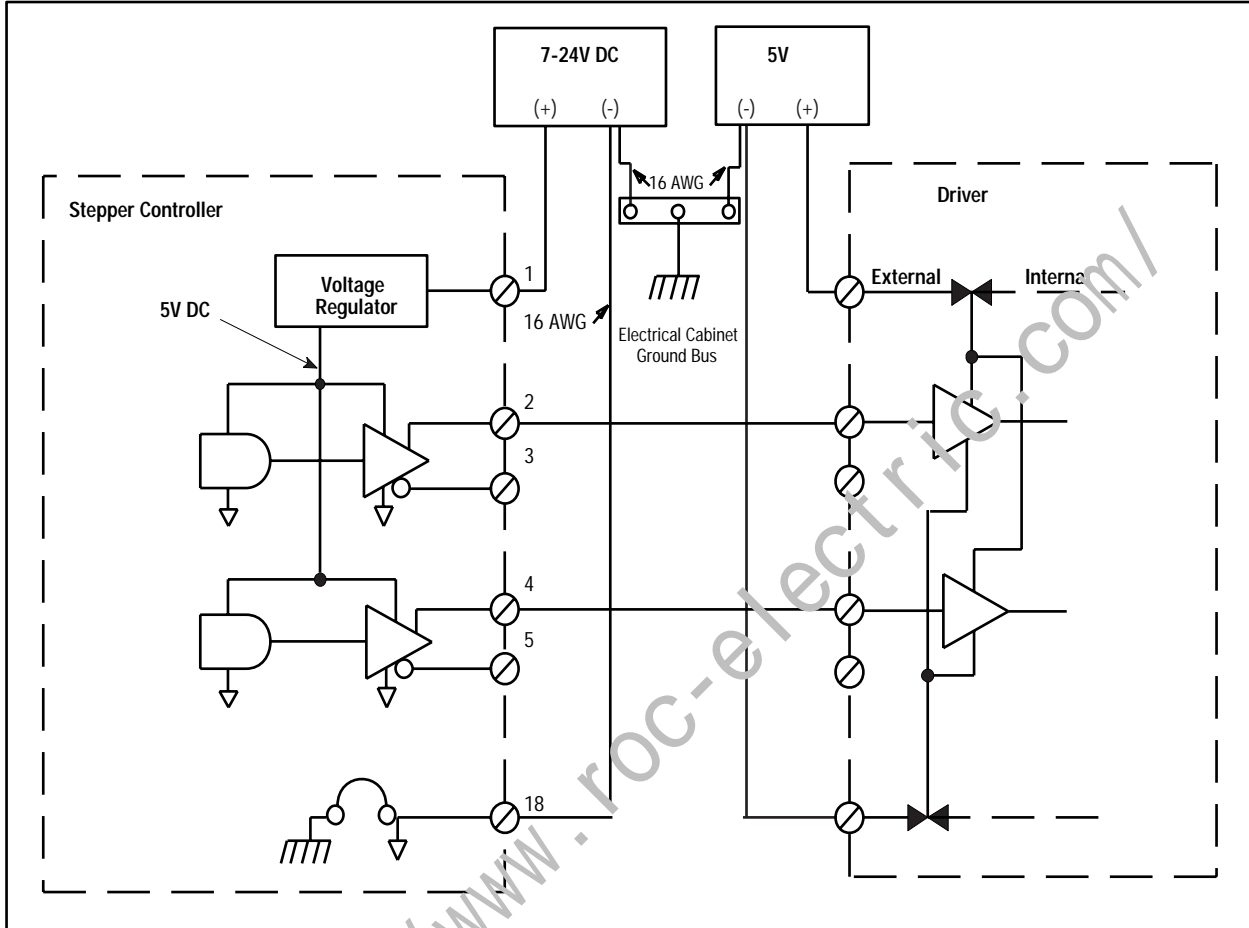

Note: Use this wiring information when connecting the 1746-HSTP1 Stepper Module to a stepper translator that requires a TTL Interface. The 5V supply to the TTL interface is internal to the translator itself or a separate power supply you select. This design is probably the most sensitive to noise due to the single-ended high-speed nature of the TTL devices. For that reason, only use it if the stepper translator is in close proximity to the controller (five cable feet or less in an enclosure well shielded from EMI noise when the cabinet doors are closed).

General Specifications

This section contains the power requirements, storage and operating conditions, and the effect on the SLC processor scan time.

Power Requirements

Specification	Description
Backplane 5V DC	0.2 A
User Power 24V DC	0.09 A maximum

Storage and Operating Conditions

Specification	Description
Storage Temperature	-40° to 85°C (-40° to 185°F)
Operating/Inlet Air Temperature	0° to 60°C (32° to 140°F)
Altitude	up to 200 m (6562 ft)
Humidity	5 to 95% non-condensing

Effect on SLC Processor Scan Time

Scan time effect is the amount of time the SLC processor spends processing the overhead associated with each module. Scan time effect is included in the time required to scan the application logic in the processor. In other words, the more modules in your rack, the slower the application scan rate will be.

Use the following data to determine the scan time effect on the SLC processor. To calculate the total scan time effect of all modules in the rack, refer to *System Parameters* in publication number 1747-6.1.2.

Processor	Input Scan	Output Scan
5/01	2.0 ms	2.0 ms
5/02	1.2 ms	1.2 ms
5/03	470 µs	520 µs
5/04	450 µs	500 µs
5/05		

<http://www.roc-electric.com/>

<http://www.roc-electric.com/>

RSLogix 500, SLC, SLC 500, SLC 5/01, SLC 5/02, SLC 5/03, SLC 5/04, and SLC 5/05 are trademarks of the Allen-Bradley Company, In Allen-Bradley and PLC are registered trademarks of the Allen-Bradley Company, Inc.
UL is a registered trademark of Underwriters Laboratories.

www.rockwellautomation.com

Power, Control and Information Solutions Headquarters

Americas: Rockwell Automation, 1201 South Second Street, Milwaukee, WI 53204-2496 USA, Tel: (1) 414.382.2000, Fax: (1) 414.382.4444
Europe/Middle East/Africa: Rockwell Automation, Vorstlaan/Boulevard du Souverain 36, 1170 Brussels, Belgium, Tel: (32) 2 663 0600, Fax: (32) 2 663 0640
Asia Pacific: Rockwell Automation, Level 14, Core F, Cyberport 3, 100 Cyberport Road, Hong Kong, Tel: (852) 2887 4788, Fax: (852) 2508 1846

Publication 1746-2.39 — April 2000
Supersedes Publication 1746-2.39 — June 1997

2000 Rockwell International. All Rights Reserved. Printed in the U.S.A.